

# Device Description

## Dashboard

- 1 Controller PROGRAMS
- 2 PANEL IGNITION
- 3 DISPLAY
- 4 THERMOSTAT/TIME SELECTION controller
- 5 START-UP / SHUTDOWN
- 6 Icône FAST CLEAN
- 7 TIMER icon
- 8 TIME SELECTION icon
- 9 DOOR LOCK / CONTROLS icon
- 10 LIGHTING ICON

## Display

- 11 Numbers TEMPERATURE and TIME
- 12 Icon DURATION
- 13 END COOKING icon
- 14 Icône WATCH
- 15 TIMER ICON
- 16 LOCKED DOOR indicator
- 17 KEYPAD LOCKED indicator light
- 18 Preheat / Waste Heat Indicator
- 19 Icons PROGRAMS

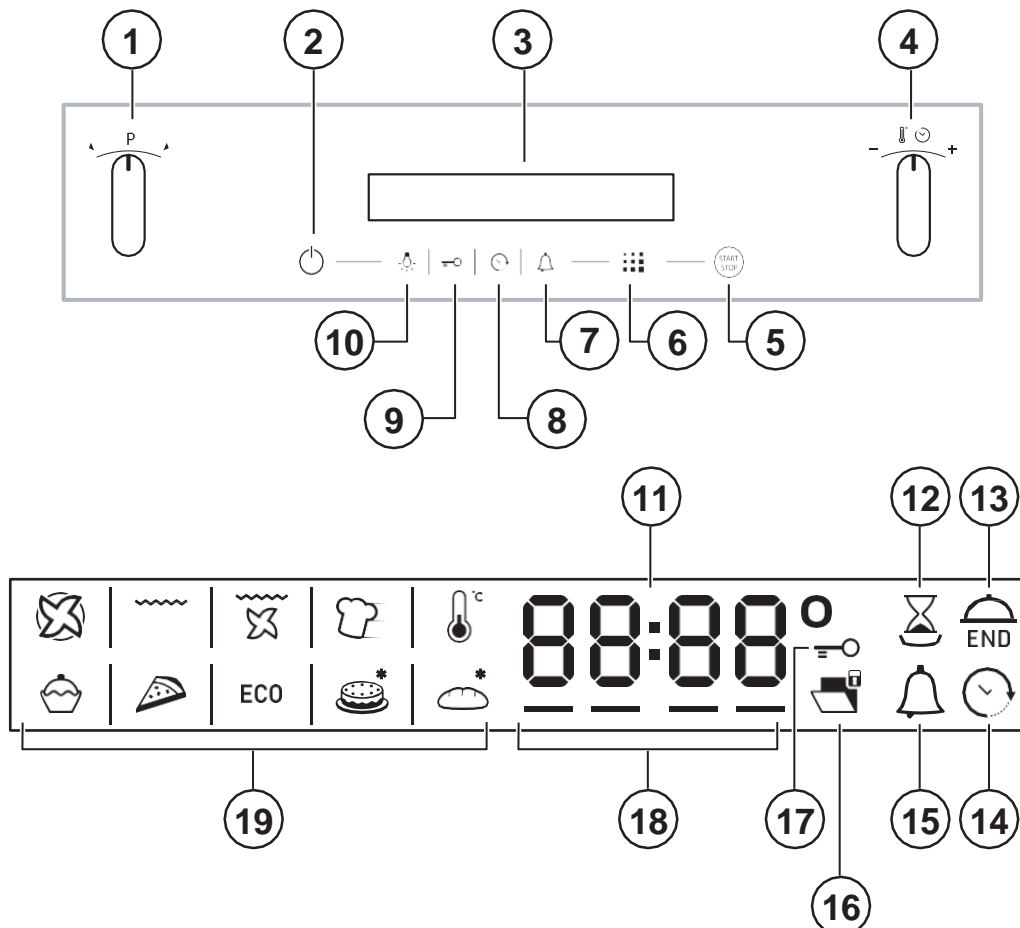

## Start-up and use

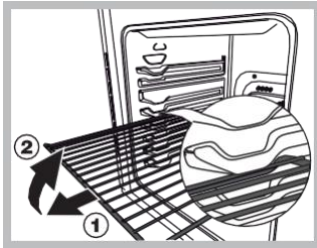

**CAREFUL!** The oven is equipped with a rack stop system that allows them to be removed without the racks leaving the oven entirely (1).

To completely remove the grilles, it is sufficient, as illustrated, to lift them in

seizing them from the front and pulling them out (2).

! When first turning it on, run the oven empty, door closed, for at least one hour, setting the thermostat to maximum. Then turn off the oven, open the door and ventilate the room. The smell is due to the evaporation of the products used to protect the oven.

! To simplify the selections, keep the button in place: the numbers scroll faster.

! Each selection is automatically remembered for 10 seconds.

! When you wear the gloves, it is impossible to operate the buttons.

Some models are equipped with a hinge system that allows the door to close slowly without having to accompany it with your hand. For proper use, before closing:



- Open the door completely.
- Avoid manually forcing the closure.

! To optimize cooking performance, an adjustment of the product parameters is made at the time of activation of the selected function, this may cause a delay in the ignition of the fan and the elements

Heating.

### Control Lock

! Controls can be locked with oven off, cooking or finished or programmed.

To lock the oven door and controls, press the button  for at least 2 seconds. An audible signal sounds and the "n-O" key symbol appears on the display. The icons 

and  lights indicate that the lock is activated.

To unlock, press the button again  for at least 2 seconds.

! When cleaning the device, it may happen that it closes inadvertently the door lock (a spring is visible). In this case, bring it back to the open position by turning the door lock upwards (see figure).

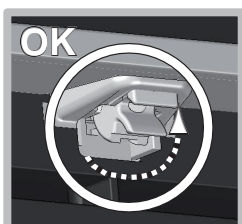



### Set the clock

! The clock is only adjustable when the oven is turned off. If the oven is in standby mode, a first press of the button  displays current time. Press again to set the time.

After connection to the mains or after a power failure, the button  and numbers on the display will start flashing for 10 seconds.

To set the clock:



1. Press the button .
2. turn the TIME SELECTION knob to "+" or "-" and set the time.
3. Once the exact time is reached, press again the key. 
4. proceed as indicated above for the minutes as well. In the event of a power outage, the clock must be reset to the time. The flashing icon  on the display indicates that the clock needs to be set.

### Set the timer

! The timer is always adjustable both with the oven off and with the oven off lit. It does not control the turning on and off of the oven.



After the time has elapsed, the timer will beep and automatically stop after 30 seconds or after any active key is pressed.

To set the timer:

1. Press the button .
2. Set the desired time by turning the TIME SELECTION knob to "+" or "-".
3. Once you have reached the desired selection, press again on the sidelines .

The lit icon  indicates that the timer is activated.

The DISPLAY displays the countdown.

To cancel the timer selection, press the key  and use the button to bring the time back to 00:00. Press the button again .

The off icon  indicates that the timer is off.

### Turning on the oven

1. Press the button  to turn on the control panel. The device emits a triple upward sound and all the keys light up in a row.

2. To select the desired cooking program, turn the PROGRAMS knob. The screen displays:  
- in the case of a manual program, the temperature associated with the program;  
- alternating "Auto" and the duration in case of automatic program.

3. Press the button to start cooking.

4. The oven is placed in preheating, the temperature rise indicators gradually light up as the temperature increases.

5. An audible signal followed by the illumination of all warm-up indicators signals the end of warm-up. It's time to put the dishes in the oven.

6. During cooking, it is possible at any time to:

- Change the temperature by turning the THERMOSTAT knob

(only manual programs);

- program the duration of a cooking (see Programs);

- Stop cooking by pressing the button . In this case, the device remembers the temperature that may have been changed previously (only for manual programs).

- Turn off the oven by holding down the button  for 3 seconds.

7. In the event of a power cut, if the temperature of the oven has not dropped too much, a special device will restart the program from the moment it has been interrupted. However, the schedules awaiting start-up are not restored and must be reprogrammed as soon as the power is restored (for example: a cooking start has been scheduled for 8:30 p.m. At 7:30 p.m., there is a power cut. After the power is restored, it is necessary to reprogram).

! No preheating is planned for the program BARBECUE.

! Never place objects directly on the oven floor, as the enamel may be damaged.

! Always put the dishes in the oven on the rack provided with the appliance.

! The oven is placed in preheating 2 seconds after selecting the desired cycle.

### Cooling ventilation

To lower outside temperatures, a cooling system blows air outside through a slot between the dashboard, the oven door and the lower part of the oven door. In the FAST COOKING program, the fan is activated automatically.

! The fan continues to rotate after the oven is turned off until the latter has cooled down sufficiently.

### Oven lighting

The lighting turns on when the oven door is opened or a cooking program is started.

In the case of models equipped with INSIDE LEDs, when cooking starts, the LEDs on the door light up to have better lighting of all cooking levels.



The key  allows you to turn the lights on or off at any time.

### Residual heat indicators

This appliance is equipped with a residual heat indicator. When the oven is turned off, the display signals the presence of temperature inside the enclosure by turning on the "residual heat" bar. The bar elements turn off as the temperature inside the oven drops.

### Factory reset

The oven can return to its factory setting settings by simply resetting all user selections (custom clock and times). To reset, turn off the oven, continue to turn the PROGRAMS knob clockwise

of a watch and press the button at the same time  for 6 seconds. Once the reset has taken place, an audible signal will sound. From the first press of the button , it is back to the first commissioning.

### Standby

This product complies with the new European Directive on the reduction of energy consumption in standby mode. Without operations for 30 minutes and if no key or door locks have been selected, the device automatically goes into standby mode. The standby mode is indicated by the high brightness of the "Clock Icon". At the slightest intervention on the device, the system returns to normal operating mode.

## Programmes

! To obtain perfectly soft and crunchy food, the moisture it gives off is reused by the oven in the form of water vapour. This ensures optimal cooking results for all dishes.

! Each time you turn it on, the oven offers the first manual cooking program.

### Manual cooking programs

! All programs have a pre-selected cooking temperature. It can be set manually, between 30 and 250°C (300°C for the BARBECUE program). Any change in temperature will be memorized and reposed the next time the program is used. If the temperature you choose is higher than the oven's interior temperature, the display will display "Hot". However, it is possible to start cooking.

#### MULTILEVEL Program

The heat is constant and well distributed inside the oven, the air cooks and browns evenly in all respects. It is possible to cook a maximum of two levels at the same time.

~~~~~

#### BARBECUE Program

Turning on the arch resistor and rotisserie (if equipped). The high and direct temperature of the grill is recommended for all foods that require a high temperature on the surface. Baking should take place with the oven door closed (see "Cooking tips").

~~~~~

#### GRATIN Program

Switching on the arch resistor, the circular resistor (for a certain time) and the turbine and rotisserie (if equipped). Unidirectional thermal irradiation is combined with air circulation for even heat distribution throughout the furnace enclosure. More risk of burning food on the surface and greater heat penetration. Baking should take place with the oven door closed (see "Cooking tips").

## Programme **FAST COOKING**

This program is particularly recommended for quick cooking of ready meals (frozen or pre-cooked). For best results, bake only on one level.

## **LOW TEMPERATURE programs**

This type of cooking allows you to rise the dough, defrost, prepare yogurt, reheat more or less quickly and cook slowly at a low temperature. Selectable temperatures: 40, 65, 90°C.

## **PASTRY Program**

Turning on the rear resistor and impeller to achieve a gentle and even heat inside the oven. This function is particularly suitable for baking delicacies (such as leavened cakes).

## Programme **PIZZA**

Switching on the arch and circular resistors as well as the turbine. This combination allows the oven to heat up quickly. If cooking on several levels, do not forget to change their place halfway through cooking.

## Programme **ECO**

Turn on the rear resistor and fan to get a gentle and even heat inside the oven. This low-energy mode is recommended for small dishes, it is ideal for heating food and finishing cooking.

## **Rotisserie\***

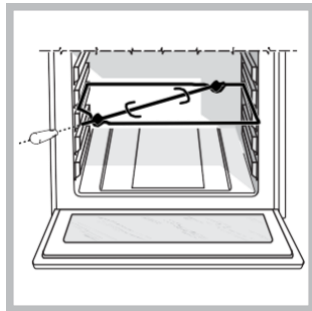

To activate the rotisserie (see figure), proceed as follows:

1. place the drip pan at level 1;
2. Place the cradle at level 3 and insert the rear end of the pin into the hole at the bottom of the speaker.
3. to operate the

rotisserie select programs or;

! When both programs  are started, the rotisserie stops as soon as the oven door is opened.

## **Automatic cooking programs**

! The cooking temperature and duration are pre-selected using the C.O.P. ® (Optimally Programmed Cooking) system, which automatically guarantees a perfect result. Cooking stops automatically and the oven signals that the dish is cooked. It is possible to bake cold or hot.

Possibility to customize the cooking time according to your needs.

personal tastes by modifying it, before starting, by

±5/20 minutes depending on the program chosen. Changing the time is also possible during cooking. If this change is made before the program starts, it is stored and reproposed the next time the program is used. If the interior temperature of the oven is higher than that offered by the chosen program, the display displays the message "Hot" and cooking cannot be started

: you have to wait for the oven to cool down.

! A beep indicates that cooking is complete.

! To avoid distorting cooking times and altering temperatures, do not open the oven door.

## **CAKES Program**

This function is the best for baking cakes made with baker's yeast, baking powder or without yeast. Bake cold. It is also possible to put it in hot ovens.

## Programme **PAIN**

This is the ideal function for baking bread. For best results, we recommend carefully following the following tips:

- follow the recipe exactly;
- Respecting **the maximum weight** for each plate;
- **Don't forget to pour 50 g (0.5 dl) of cold water into the drip pan at step 5;**
- Rise the dough at room temperature for 1 hour or 1 1/2 hours, depending on the room temperature and until it has almost doubled in size.

## **Recipe for BREAD:**

1 1000g Maxi plate. Lower Tier

2 Plates of 1000g Maxi. Lower and middle tiers

Recipe for 1000g of dough: 600g of flour, 360g of water, 11g of salt, 25g of fresh baker's yeast (or 2 sachets of powder)

Process:

- Combine the flour and salt in a large bowl.
- Dilute the baker's yeast in water slightly warm (about 35 degrees).
- Place the flour in a fountain.
- Pour in the water and yeast mixture
- Mix and knead until you get a homogeneous and not sticky dough, stretch it with the palm of your hand and fold it over itself for 10 minutes.
- Form a ball, place it in a bowl and cover with plastic wrap to prevent the surface of the dough from drying out. Slide the bowl into the oven, select the manual **LOW TEMPERATURE** function at 40°C and let rise for about 1 hour (the dough should double in size)
- Divide the ball to obtain several loaves.
- Place them on the paper-lined baking sheet Parchment.
- Sprinkle the loaves with flour.
- Make cuts on the loaves.
- Bake cold.

\* Only available on select models





- Start baking  BREAD \*
- At the end of cooking, let the loaves rest on a rack until they have cooled completely.

roisserie, place the drip pan on step 1 to collect any fat or cooking juices.

## How to Schedule a Bake

! Programming is only possible after selecting a cooking program.





### Program the cooking time

1. Press the key  until the and  the numbers on the display start flashing;
  2. turn the TIME SELECTION knob to "+" or "-" to set the desired time; If the button is held in place, the numbers scroll faster.
  3. Once the desired time has been reached, press the button again . The screen alternates between the time and the selected temperature.
  4. Press the button  to start cooking.
  5. An audible signal indicates that cooking is complete and the display displays "END".
- Example: it is 9:00 a.m. and the scheduled duration is 1 hour and 15 minutes. The program stops automatically at 10:15 a.m.

### Programming the end of a cooking process

! It is not possible to program the end of cooking only after selecting a cooking time.

! To make the best use of deferred programming, you need to that the clock is set correctly.

1. Follow the procedure from 1 to 3 described for the duration;
  2. Press the key 2 times  : the icon  and the digits start flashing on the display;
  3. turn the TIME SELECTION knob to "+" or "-" and set the cooking end time.
  4. Once the final time has been reached, press the button again . The display alternately displays the cooking time, the end time and the selected temperature.
  5. Press the button to activate the program. The  icons and lights indicate that a program has been launched. The DISPLAY alternately displays the cooking end time and the duration.
  6. An audible signal indicates that cooking is complete and the display displays "END".
- Example: it is 9:00 am, the scheduled duration is 1 hour 15 minutes and the final time is set at 12:30 pm. The program starts automatically at 11:15 am.

To cancel a program, press the button .

## Cooking tips

! For ventilated cooking, do not use bleachers 1 and 5: they are directly hit by hot air which could burn the delicatessen.

! For BARBECUE and GRATIN cooking, especially with a

---

## MULTILEVEL

- Use levels 2 and 4 and place dishes that require more heat on 2.
- Place the broiler pan at the bottom and the rack at the top.

## BARBECUE

- Place the rack in steps 3 or 4, put the dishes in the oven middle of the grid.
- We recommend selecting the highest temperature. Do not worry if the top resistor is not on all the time: its operation is controlled by a thermostat.

## FOUR PIZZA

- Use a light aluminum dish and place it on the oven rack.  
If you use the enamel tray, the cooking time will be longer and the pizza will be much less crispy.
- If the pizzas are well garnished, do not add the mozzarella halfway through cooking.

## Cooking table

\*

Programmes	Food	Weight (kg)	Charging level		Preheating	Recommended temperature (°C)	Cooking time (minutes)
			Standard Slides	sliding slides			
	<b>Manuals</b>						
<b>Multilevel*</b>	Pizza on 2 levels		2 and 4	1 and 3	oui	210-220	20-25
	Pies on 2 levels/cakes on 2 levels		2 and 4	1 and 3	oui	180	30-35
	Sponge cake on 2 levels (on enamelled tray)	1+1	2 and 4	1 and 3	oui	160-170	20-25
	Roast chicken + potatoes		2 and 4	1 and 3	oui	200-210	65-75
	Lamb Mackerel	1	1 and 2/3	1 and 3	oui	190-200	45-50
	Lasagna	1	2	1	oui	180	30-35
		1	1 or 2	1	oui	180	30-35
	Cabbages on 3 levels		2	1	oui	180-190	35-40
	Cookies on 3 levels		1 and 3 and 5	1 and 2 and 4	oui	190	20-25
	Cheese treats on 2 levels		5	1 and 2 and 4	oui	180	10-20
Savoury pies		1 and 3 and 5	1 and 2	oui	210	20-25	
<b>Barbecue*</b>	Mackerel Soles and cuttlefish	1	4	3	not	300	15-20
	Squid and shrimp skewers	0,7	4	3	not	300	10-15
	Slices of hake	0,7	4	3	not	300	8-10
	Grilled vegetables	0,7	4	3	not	300	10-15
	Veal chop	0,5	3 or 4	2 or 3	Not	300	15-20
	Sausages	0,8	4	3	not	300	15-20
	Hamburgers	0,7	4	3	not	300	15-20
	Croque-monsieur or toast	4 or 5	4	3		300	10-12
	Rotisserie chicken with rotisserie (yes present)	4 or 6	4	3		300	3-5
	Roast lamb with rotisserie (yes present)	4	4	3		300	70-80
		4	4	3		300	70-80
<b>Gratin*</b>	Grilled chicken	1,5	2	2	not	210	55-60
	cuttlefish	1	2	2	not	200	30-35
	Rotisserie chicken with rotisserie (yes present)	1,5	-	-	not	210	70-80
	Roast duck with rotisserie (yes present)	1,5	-	-	not	210	60-70
	Roast veal or beef	1	2	2		210	60-75
	Roast pork	1	2	2		210	70-80
	Lamb	1	2	2		210	70-80
<b>Fast cooking*</b>	<b>Frozen</b>						
	Pizza	0,3	2	1	-	250	12
	Mix of zucchini and shrimp in crust	0,4	2	1	-	200	20
	Spinach puff pastry	0,5	2	1	-	220	30-35
	Salty turnovers	0,3	2	1	-	200	25
	Lasagna	0,5	2	1	-	200	35
	French Rolls	0,4	2	1	-	180	25-30
	Chicken chunks	0,4	2	1	-	220	15-20
	<b>Precooked</b>						
	Golden Chicken Wings	0,4	2	1	-	200	20-25
	<b>Fresh Food</b>						
Cookies (shortcrust pastry)	0,3	2	1	-	200	15-18	
Fruit cake	0,6	2	1	-	180	45	
Friands au fromage	0,2	2	1	-	210	10-12	
<b>Low temperature*</b>	Proofing / defrosting White meringues Meat/Fish	-	2	1	No	40	-
		-	2	1	no	65	8-12 hours
		-	2	1	no	90	90-180
<b>Pastry*</b>	Pies	0,5	2 or 3	1 or 2	oui	180	25-35
	Fruit pie	1	2 or 3	1 or 2	oui	180	40-50
	Fruit cake	0,7	2 or 3	1 or 2	oui	170-180	45-55
	Cupcakes on 2 levels	0,7	2 and 4	1 and 3	oui	180-190	20-25
	Genoise	0,6	2 or 3	1 or 2	oui	160-170	30-40
	Cabbages on 3 levels	0,7	1 and 3 and 5	1 and 2 and 4	oui	180-190	20-25
	Cookies on 3 levels	0,7	1 and 3 and 5	1 and 2 and 4	oui	180	20-25
	Crêpes farcies	0,8	2	1	oui	200	30-35
	Meringues on 3 levels	0,8	2	1	oui	200	30-35
	Friands au fromage	0,5	1 and 3 and 5	1 and 2 and 4	oui	90	180
<b>Pizza*</b>	Pizza Fougasses	0,5	2	1	Yes,	210-220	15-20
		0,5	2	1	yes	190-200	20-25
<b>Automatic**</b>							
<b>Cakes</b>	Cakes	1	2 or 3	2	Not		
<b>Pain***</b>	Bread (see recipe)	1	1 or 2	1	Not		

\*Cooking times are purely indicative and can be modified according to individual tastes. Oven warm-up times are pre-selected and cannot be changed manually.

\*\*Automatic cooking times are pre-selected. These values can be changed by the user from the pre-selected duration.

As directed in the recipe, add 50 g (0.5 dl) of water to the drip pan set at level 5.

**! ECO program:** This program is ideal for cooking fish fillets, small pastries and vegetables, which saves a lot of energy. It is just as ideal for reheating dishes and completing cooking.